

Operator's Manual and
Replacement Parts List for the

M8274-50
WINCH



As you read these instructions, you will see NOTES, CAUTIONS and WARNINGS. Each message has a specific purpose. NOTES are additional information to help you complete a procedure. CAUTIONS are safety messages that indicate a potentially hazardous situation which, if not avoided, may result in minor or moderate injury. A CAUTION may also be used to alert against unsafe practice. WARNINGS are safety messages that indicate a potentially hazardous situation, which, if not avoided could result in serious injury. CAUTIONS and WARNINGS identify the hazard, indicate how to avoid hazard, and advise of the probable consequence of not avoiding the hazard. PLEASE WORK SAFELY!



GENERAL SAFETY PRECAUTIONS



WARNING!

MOVING PART HAZARD

To prevent serious injury and property damage:



- Do not operate or install winch without reading and understanding the operator's manual.



- Keep hands clear of wire rope, hook and fairlead opening during operation and when spooling.



- Use supplied hook strap for spooling wire rope.



- Stand clear of wire rope and load during operation.

- Keep others away.

- Inspect winch installation and wire rope condition before operating winch.



- Do not use as a hoist



- Do not use to move persons

- Do not exceed winch's rated capacity.



- Never touch wire rope or hook while in tension.

- Be certain the anchor you select will withstand load.



- Never wrap wire rope back onto itself.

- Use a choker chain, wire choker rope or tree trunk protector on the anchor.

- Prior to initiating winching operation be sure any element which can interfere with safe winching operations is removed.

- Take your time. Sloppy rigging causes accidents.



WARNING!

- Do not disengage clutch if winch is under load or wire rope is in tension.
- This winch is capable of exceptionally high line speeds and may exceed published line speeds. Use extreme caution when handling hook and wire rope during spooling operations.



CAUTION!

To avoid injury and property damage:

KNOW YOUR WINCH: Take time to fully understand your winch and the winching operation.



- Do not use winch to secure a load during transport



- Do not submerge in water



- Wear heavy leather gloves when handling the wire rope.



- Never winch with less than 5 wraps of wire rope around the drum.

WHEN USING THE REMOTE CONTROL:

- Do not leave remote control plugged into winch while free-spooling, rigging, or sitting idle.
- Before winching, inspect remote control lead for damage.
- When using remote control inside a vehicle, always pass it through a window to avoid pinching lead in door.
- Store the remote control in a protected, clean, dry area.

Winch Mounting

- Choose a mounting location that is sufficiently strong enough to withstand the loads you intend to winch.
- **Find the diagrams of your winch on the following pages. Refer to them for proper orientation.** Only the mounting orientation shown is possible for safe winching operation. All others are improper and inappropriate.
- The wire rope must always spool onto the drum as indicated by the drum rotation decal.
- The use of recommended bolt and lock washer combinations torqued to recommended levels will prevent vibration during operation.

Find the diagrams of your winch on the following pages. Refer to them for proper torque levels.

Solenoid Pack Installation

- All "P" series winches include a built-in, integrated solenoid – no installation is necessary.
- For all other winches:
- Mount the control pack according to the instructions included in the Warn mounting system kit. Use the bracket included in the kit.
 - To mount the control pack directly to the winch, order control pack bracket part number 26368.

Electrical Connections

- Make sure to use the insulating boots on the exposed connections to prevent electrical shorting. Route battery connection cables in areas which will not cause them to chafe or cut through the insulation causing a potential short circuit.
- Upon completion of installation, check winch for proper operation.

Refer to the electrical circuit diagram below and the diagrams for your winch on the following pages.

ELECTRICAL CIRCUIT DIAGRAM

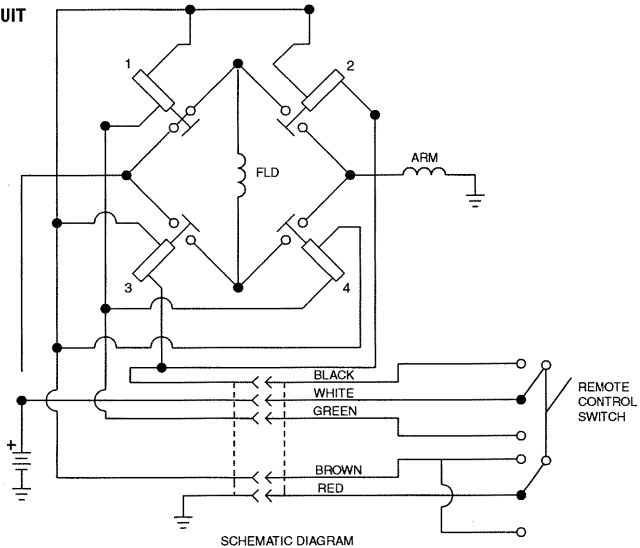

M8274-50

M8274-50 SPECIFICATIONS

Part Number:
PN 38631

Rated Line Pull:
8000 lbs./3600 kgs. (single-line)

Motor:
4.6 hp, Series Wound

Control:
Remote switch, 12'/3.7m lead

Gear Train:
Spur Gear

Gear Ratio:
134:1

Lubrication:
6 oz. SAE 30 (non detergent)

Clutch [freespooling]:
Sliding Motor Pinion Gear

Brake:
Automatic, disc type

Drum Diameter/Length:
3.5"/8.5", 9cm/22cm

Weight: 110 lbs./50 kgs.

Wire Rope:
150', 5/16" diameter
46m, 8mm diameter

Fairlead: Included

Remote Control: Included

Recommended Battery:
650 CCA minimum for winching

Battery Leads:
2 gauge, 72"/1.83m

Finish: Argent Powder Coat with Clear Coat

APPLICATION INFORMATION

- **This is a winch, not a hoist.** Use only to slide loads. Never lift a load by the winch.
- Maximum single line pulling capacity: 8000 lb. [3600 KG].
- 12 Volts DC.

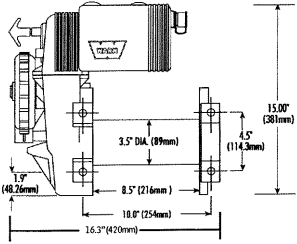

16.3" L. x 8.5" D. x 15" H.
420mm L. x 220mm D. x 381mm H.

12V DC PERFORMANCE SPECS (FIRST LAYER OF DRUM)

Line Pull lbs. (kgs)	Line Speed ft. min. (m/min)	Motor Current (Amps)
0	73.4 (22.37)	55
2000 (907)	22.0 (6.71)	190
4000 (1814)	12.0 (3.66)	275
6000 (2722)	9.50 (2.90)	350
8000 (3629)	6.10 (1.86)	450

M8274-50 WINCH MOUNTING

Mounting location:

- (1) Smooth and flat, thickness = 1/4" (6.4MM)
- (2) 7/16 lockwasher X 4
- (3) 7/16 - 14 x 1-1/2, grade 5 bolt x 4 torque 45-50 FT. LBS.

Mounting bolt pattern:

10.0" x 4.5",
254mm x 114.3mm

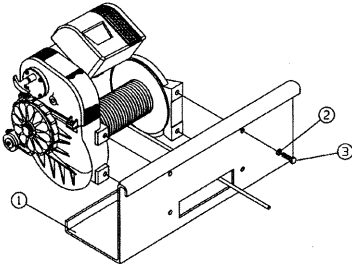
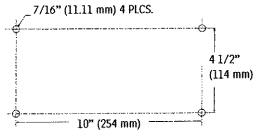

M8274-50 ELECTRICAL CONNECTIONS

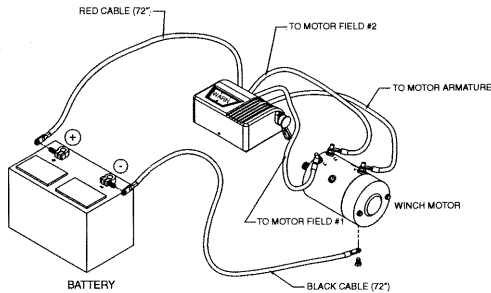

WINCH OPERATOR'S MANUAL

GO PREPARED™



CAUTION!

KNOW YOUR WINCH: Take time to fully understand your winch and the winching operation.

REMOTE CONTROL SWITCH

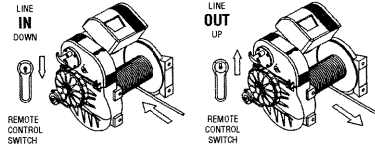

CLUTCH OPERATION



WARNING!

To prevent serious injury and property damage:

- Do not disengage clutch if winch is under load or wire rope is in tension.

When the clutch is engaged the gear train is coupled to the wire rope drum and power may be transferred from the winch motor. When the clutch is in free spool the gear train and wire rope drum are uncoupled allowing the drum to rotate freely. The clutch knob, located on the winch housing opposite the motor, controls the clutch position. To prevent damage, always fully engage or fully disengage the clutch knob.

OVERLOADING/OVERHEATING

This winch is rated for intermittent duty. When the motor approaches stall speed, very rapid heat buildup occurs which may cause motor damage.

Double-line rigging (see Rigging section) will reduce the amperage draw, and reduce heat buildup in the motor. This allows longer continual use.

OPERATOR'S SAFE WORKING STATIONS

The operator should always operate the winch in a safe position while pulling a load. The safe areas are perpendicular to the wire rope or in the vehicle with the hood up (if winch is mounted on front of vehicle). This will help prevent the wire rope from striking the operator if it fails under load. Operate the winch, when possible, at the end of the remote control length. The operator must be at least 8 ft (2.5m) from the winch while operating. This will prevent entanglement with the fairlead and keep the operator out of harm's way during winch load pulling.

Never work around wire rope while under load.

BATTERY RECOMMENDATIONS

A fully charged battery and good connections are essential to the proper operation of your winch. The minimum requirement for a 12 volt DC battery is 650 Cold Cranking Amperes.

MAINTENANCE

- No lubrication is required for the life of the winch, unless the winch is submerged in water. If this occurs, a qualified service center must complete service as soon as possible to prevent corrosion damage. If the control pack is submerged, it must be replaced when the winch is serviced.
- Check battery cables and electrical connections at 90 day intervals to be certain they are clean and tight at all connection points.
- Inspect the wire rope before and after each winching operation. Replace when damaged.
- The wire rope must always spool onto the drum as indicated by the drum rotation decal on the winch.

WINCHING



CAUTION!



To avoid injury and property damage:

- Wear heavy leather gloves when handling the wire rope.
- Never winch with less than 5 wraps of wire rope around the drum.

SPOOLING



WARNING!

To prevent serious injury:

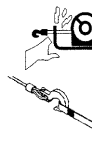

- Keep hands clear of wire rope, hook and fairlead opening during operation and when spooling.
- Use supplied hook strap for spooling wire rope.

STRETCHING WIRE ROPE

- The life of a wire rope is directly related to the use and care it receives. During its first use, a new wire rope must be spooled onto its drum under a load of at least 500 lb. [227 KG]. Spool out the wire rope to the last 5 wraps on the drum, then power in the wire rope under a load of 500 lb. [227 KG] or more. This will stretch new wire rope and create a good wire wrap around the drum. Failure to do so will result in the outer wire wraps drawing into the inner wraps, binding, and damaging the wire rope.

SPOOLING OUT

- Freespooling is generally the quickest and easiest way to spool out wire rope. Before freespooling wire rope out from the winch, power out enough rope to remove any tension the wire rope may be under. Disengage the clutch. Now freespool by manually spooling out enough wire rope for the winching operation. Always leave at least 5 wraps on the drum.

SPOOLING IN UNDER LOAD

- Power in the wire rope evenly and tightly on the drum. This prevents the outer wire wraps from drawing into the inner wraps, binding, and damaging the wire rope.
- Avoid shock loads when spooling, by using the control switch intermittently to take up wire rope slack. Shock loads can momentarily far exceed the winch and wire rope ratings.

SPOOLING IN UNDER NO LOAD

- Assisted - Have your assistant hold the hook with the hook strap putting as much constant tension on the wire rope as possible. While keeping tension, the assistant should walk toward the winch while you operate the control switch spooling in the wire rope. **Release the switch when the hook is a minimum of 8 ft [2.44 m] from the fairlead opening.** Spool in the remainder for storage.
- Unassisted - Arrange the wire rope to be spooled so it will not kink or tangle when spooled. Be sure any wire rope on the drum is tightly and evenly layered. Spool enough wire rope to complete the next full layer on the drum. **Tighten and straighten the layer. Repeat process until the hook is a minimum of 8 ft [2.44 m] from the fairlead opening.** Spool in the remainder for storage.

SPOOLING REMAINDER FOR STORAGE

- Secure the hook to a suitable anchor point near the winch. Carefully power in the remaining wire rope, jogging the control switch to take up the last of the slack. Be careful not to over tighten or damage may occur to the wire rope or anchor point.

SOUND EMISSIONS

- The winch is designed so that the sound emissions do not exceed 70 dBA from the operator's station. The operator must be at least 8 ft. (2.44m) from the winch while operating. If the winch is exceeding 70 dBA from the operator's station, have it inspected at an authorized service center.

RIGGING



WARNING!



- Stand clear of wire rope and load during operation.
- Be certain the anchor you select will withstand load.
- Never wrap wire rope back onto itself.
- Use a choker chain, wire choker rope or tree trunk protector on the anchor.
- Prior to initiating winching operation be sure any element which can interfere with safe winching operations is removed.
- Take your time. Sloppy rigging causes accidents.

- Always spool out as much wire rope as possible while leaving the last 5 wraps on the drum. Pick an anchor as far away as practical. This provides the winch with its greatest pulling power.

- Approximate pulling power:

Pulling Power	Wire Rope Layer
8000 lb. (3629 kg)	1st layer*
7460 lb. (3384 kg)	2nd layer
6980 lb. (3166 kg)	3rd layer
6620 lb. (3003 kg)	4th layer
6290 lb. (2853 kg)	5th layer

*closest to drum core

- Rigging a double line with a snatch block will reduce the load on the winch in half without significant loss of spooling speed.
- Natural anchors such as trees, stumps and rocks are the handiest when available. Attach the choker chain, wire choker rope or tree trunk protector on the anchor as low as possible to avoid pulling the anchor down. If several possible anchors are available but they are not strong enough individually, it may be practical to attach a wire or chain choker around several anchors to form a strong collective anchor point.

Single Line Pull

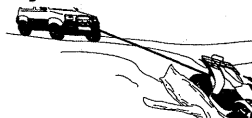

Double Line

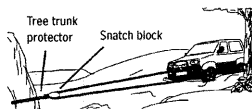

Direction Change



SERVICE CENTER INFORMATION

For a Warn Authorized Service Center near you, please call: **1-800-543-9276**

Note: Authorized service centers will need the date of manufacture, date code and serial number in order to service winch properly. This information is located on the geartrain end of winch (closest to clutch handle).

Model #: _____

Date of Manufacture: _____

Date code: _____

Date of purchase: _____

Place of purchase: _____

